



data sheet **DE-62**



DE-62 is our independent parking-system with a pit and sliders at the entrance level. Our semi-automatic system offers a high standard of comfort from the ahead of time control panel, through the easy access to the parking space.

D2

EASY TO PLAN with space saving construction.



EASY TO INSTALL with minimized parts construction.



EASY TO USE due to barrier free construction.



1. THE FUNCTIONALITY OF DE-PARK DIGITAL

Our Digital Series have a combination of lifting and sliding platforms. There is one sliding platform less than lifting platforms per system. A system with up to 10 segments and 19 parking spaces is possible.

You can choose your parking space with one touch at the control panel.

The example shows 3 grids with 5 parking places: 1 empty space is needed for the movement.

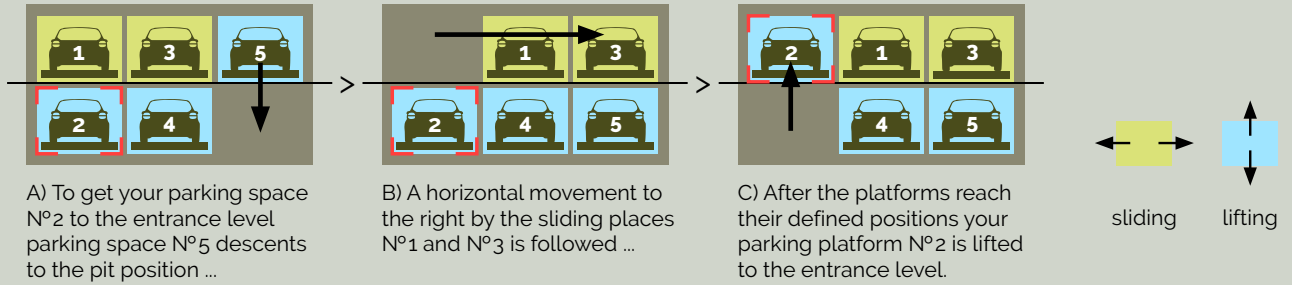

2. WIDTH OF PARKING SPACE / SYSTEM (IN CM)

- A = parking width
- B = segment width
- C = additional Space
- D = system width ^{1*}

^{1*} Tolerance of dimensions on the construction site = 0 to + 3 cm

Parking width	Segment width	Additional space
A	B	C
230	250	10
240	260	10
250	270	10
260	280	10
270	290	10

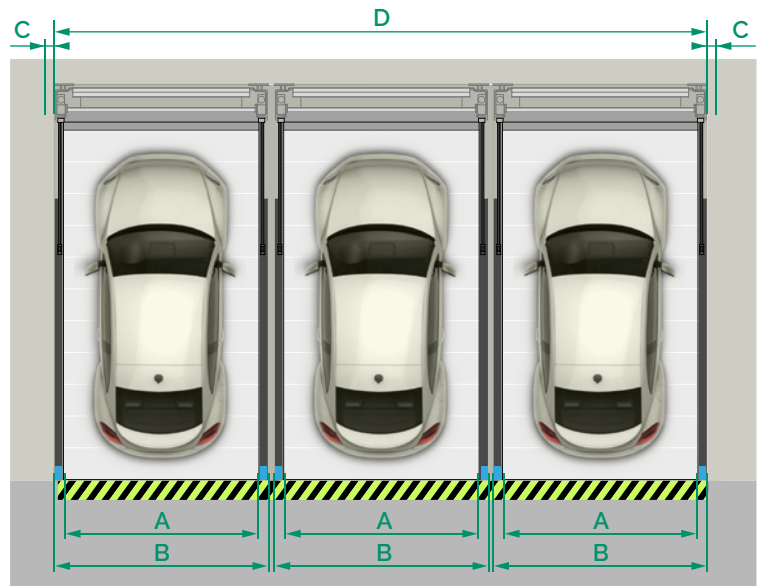

Parking width A	System width D	System width D	System width D	System width D	System width D	System width D	System width D	System width D	System width D
	2 seg. 3 cars	3 seg. 5 cars	4 seg. 7 cars	5 seg. 9 cars	6 seg. 11 cars	7 seg. 13 cars	8 seg. 15 cars	9 seg. 17 cars	10 seg. 19 cars
230	520	770	1020	1270	1520	1770	2020	2270	2520
240	540	800	1060	1320	1580	1840	2100	2360	2620
250	560	830	1100	1370	1640	1910	2180	2450	2720
260	580	860	1140	1420	1700	1980	2260	2540	2820
270	600	890	1180	1470	1760	2050	2340	2630	2920

3. PILLARS IN FRONT OF THE PARKING AREA

A	outer seg. inner seg.	A	outer seg. inner seg. inner seg. inner seg.	A	outer seg. inner seg. inner seg. inner seg. inner seg. inner seg.
230	250 230	230	500 480	230	750 730
240	260 240	240	520 500	240	780 760
250	270 250	250	540 520	250	810 790
260	280 260	260	560 540	260	840 820
270	290 270	270	580 560	270	870 840
	min.20		min.20		min.20

4. DIMENSIONS (IN CM)

D = pit depth
 H = clear height
 C1/C2 = vehicle height bottom / top ^{2*}

D	C1	H	C2
175 -->	150	195 -->	185
180 -->	155	200 -->	190
200 -->	175	220 -->	210
210 -->	185	230 -->	220
220 -->	195	240 -->	230
230 -->	205	250 -->	240

↑

^{2*} The vehicle height with roof rails, antenna and other height increases must not exceed the listed max. vehicle heights.

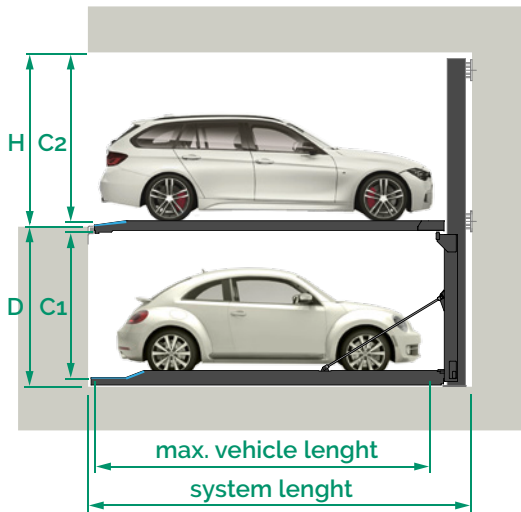

5. TECHNICAL DATA

Height

In areas with higher ceilings, taller vehicles can be parked on the top platform accordingly.

System length

For a 500 cm car length a 555 cm system length is necessary. A system length of 560 cm or 570 cm is recommended. This enables larger safety distances, if newer, longer vehicles are purchased.

Dimensions

- All dimensions are minimum finished dimensions in cm.
- Allow for tolerances to VOB Part C (DIN 18330, 18331) and additionally DIN 18202 (+ 30 mm / 0 mm).
- In case of partition walls 15x15 cm opening for hydraulik pipes are necessary in the walls. Do not close the opening after the installation.

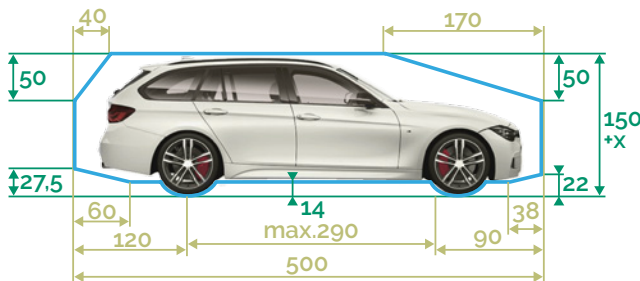

Maximum vehicle weight

- 2000kg / 500kg wheel load
- 2600kg / 650kg wheel load

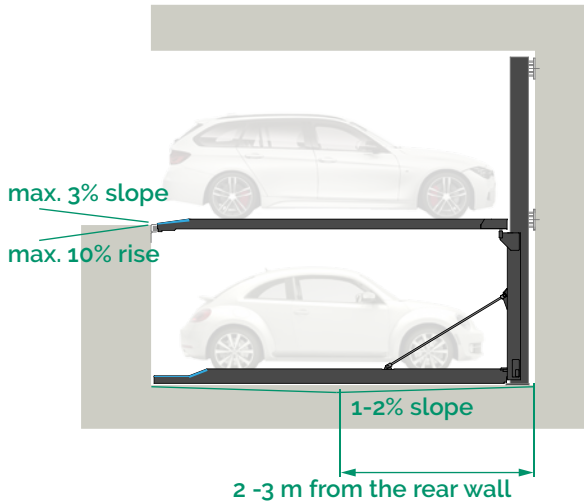

6. ACCESS CONDITIONS

With our innovative design, the accessibility of the parking place is simpler. Our flat profile over the complete platform provides higher level of comfort and driving safety. The straight entrance level and the reduced side beam of the lifting platform allow easy manoeuvring and reduce the risk of wheel collision.

Maximum slope / rise

- Max. 3% slope ^{3*}
- Max. 10% rise ^{3*}

Drainage

- 1-2 % slope on the pit floor

^{3*} In case of higher values, safe access of the vehicle cannot be guaranteed by DE-PARK.

7. ANCHORING

- Systems are anchored into the floor and rear wall. The hole depth is approx. 13 cm.
- The quality of the concrete in the structure (for the parking system) must be at least C20/25.
- The precise position of the load application points depends on the selected system. For precise values, please contact DE-PARK.

8. FORCES TO THE STRUCTURE

	2000 kg	2600 kg
F1	25 kN	30 kN
F2	20 kN	25 kN
F3	8 kN	10 kN

The force F2 can also be absorbed via the ceiling (ceiling fixation available upon request).

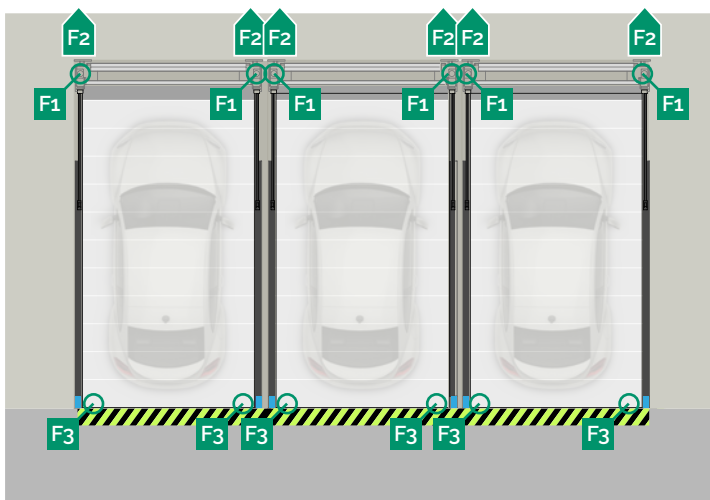
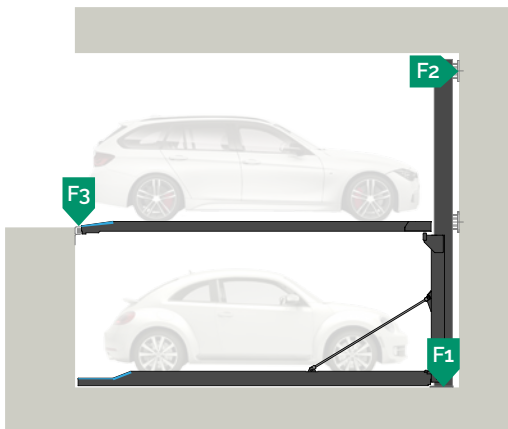



9. TYPE OF CONTROL

Interactive control unit:

Our system DE-62 is controlled digitally. With one touch you can choose your parking place by using this control unit. You can view the progress of the provision on the screen.

To be provided from customer:

Item	Description
1	Electric meter
2	Fuse or automatic circuit breaker according to DIN VDE 0100 part 430, max. 16 A
3	According to local power supply regulations 3 PH + N + PE
4	Main switch lockable
5	Connection for the protective potential equalization DIN 60204
6	Protective bonding all 10m

10. ELECTRICAL ELEMENTS

Connected load of unit: 3 kW / 400 V / 50 Hz

- The control cabinet must be placed outside the moving range of the system. We recommend positioning the cabinet near the system for a better overview of the system. The space in front of the cabinet must be minimum 1.00 m for opening the door and the operator.

Services provided in the system:

- Operator terminal including operator presence control with raising and lowering.
- Emergency stop placed outside of the system's range of movement.

Operation of the gate:

Option A – manually operated.
Option B – electrical drive per touch screen at the control unit. Additional operation with a remote control is optional.

11. GATES TO SECURE SYSTEMS WITH PIT

With our new innovative gates, we provide up to 50 cm wider entrance space than the requested parking space.

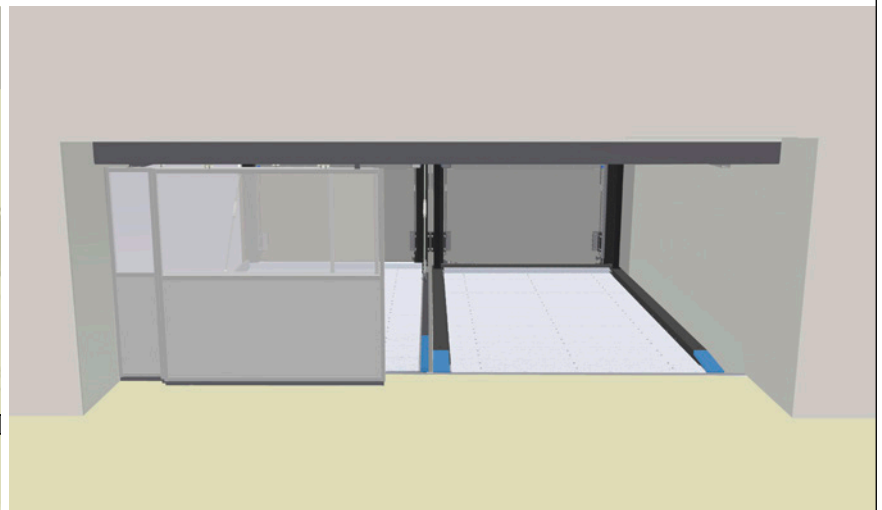
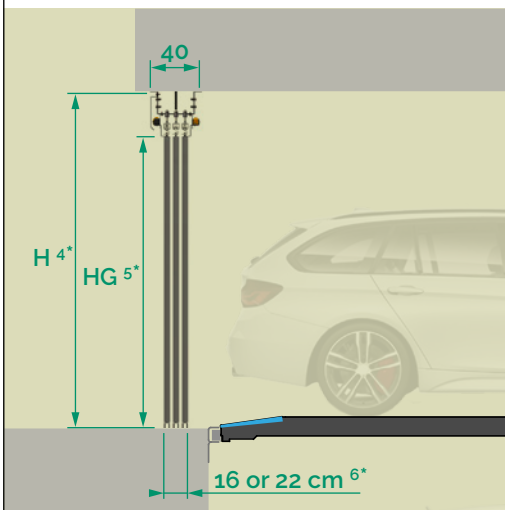

H 4* = Clear height: 225 cm
HG 5* = Entrance height: 200 cm

4* Other dimensions are available on request
5* Car height = HG - 5 cm tolerance
6* 16 cm – if gates are for 2 segments /
22 cm – if gates are for 3 segments

12. SYSTEM-RELATED REQUIREMENTS

Maintenance, cleaning & prevention

- The systems must be serviced and cleaned regularly. This applies more so if the systems and the platforms are exposed to aggressive substances such as salt, water, dirt, operating supplies, sand, etc.
- Adequate drainage must be ensured.

Ventilation

The garage must be adequately ventilated.

13. LEGAL REQUIREMENTS



Marking tape on the edge of the pit

According to EN 14010 / ISO 3864, a 10cm wide, black & yellow warning marking must be attached to the edge of the pit.



Separating elements / Barriers

According to EN ISO 13857, separating elements or barriers must be installed in the pedestrian area / accessible areas around the parking system, including during installation.



Fire safety

The garage design must fulfil the regional fire safety provisions. The requirements can vary. Therefore the situation must be clarified and information obtained in advance by the customer and then agreed and coordinated.



Noise emissions

According to the noise insulation regulations for buildings to DIN 4109, a value of 30dB (A) must be complied with in occupied rooms and spaces. You receive a sound insulation package with the system for the required 30dB (A) insulation of the structure is also necessary. Sound reduction index min. $R_w = 57\text{dB}$.

14. REQUIREMENTS ON SITE

Ambient conditions

Temperature range from -5 to +40 °C. Relative humidity max. 80%.
Please contact DE-PARK incase of different conditions.

Lighting

The parking spaces must be adequately illuminated on site as specified.

15. CE AND CONFORMITY

The systems conform to ...

- EN 14010-2009-12 Safety of Machinery - Equipment for power driven parking of motor vehicles
- Machinery Directive 2006/42/EC



Design changes

We reserve the right to continuously develop our product on the basis of technical progress and to make changes and/or modifications to parts, assemblies or overall, to processes and to standards with no advance notice.

DE-PARK IS MAKING YOUR LIFE EASY:

GERMAN MADE WITH A SLIM & MODULAR DESIGN
EASY PLANNING AND SETUP

LOW MAINTENANCE CONSTRUCTION
EASY TO USE WITH LOW NOISE EMISSIONS

NO PILLARS IN THE ENTRY AND PEDESTRIAN AREA
EASY MANOEUVERING AND SENSORLESS POSITIONING

FLAT & CONTINUOUS PLATFORM
EASY TO CLEAN AND COMFORTABLE TO WALK ON



DE-PARK GmbH
Brühl 6
04109 Leipzig
Germany

Phone: 0049 (0)341 - 24700 131
Fax: 0049 (0)341 - 24700 132
Email: info@de-park.com
Web: www.de-park.com